

Pony Express Memorial Cemetery Rules & Regulations

A. PURPOSE:

The purpose of the cemetery is to provide an affordable, peaceful, and well-maintained permanent resting place and memorial for the deceased.

B. GENERAL PROVISIONS:

The cemetery is owned by the City and shall be operated and maintained by the City or its designee. Cemetery records shall be maintained by the City or its designee.

C. DEFINITIONS:

1. "Body" means the remains of one human body (cremated or otherwise).
2. "Burial Right" means the exclusive right of the owner to use a space for the interment or other disposition of human remains.
3. "Cemetery" means the real property owned by Eagle Mountain City, used and reserved for interment of the dead.
4. "City" means Eagle Mountain City.
5. "Disinterment" means the opening or excavation of an existing space.
6. "Infant" means a fetus or a child less than two (2) years of age. Casket and vault must be less than 36 inches in length.
7. "Interment" or "Inter" means the burial of a body in a space.
8. "Lot" means an area containing eight (8) spaces.
9. "Space" means a legal and authorized gravesite generally measuring five feet by 10 feet (5' x 10') and intended for interment.
10. "Transfer" means to sell, donate, exchange, trade, or convey a burial right.
11. "Resident" means at the time of purchase:
 - a. Any person who was domiciled within City at the time of death, regardless of the actual place of death;
 - b. Any person who was a legal resident of City at the time of death; or

- c. Any person who had been domiciled in City but moved from City for the purpose of receiving medical treatment or living in a residential care facility.

D. SEXTON:

1. The City Administrator shall designate an employee or volunteer to act as the Sexton for the cemetery.
2. The Sexton shall be responsible to keep the streets, alleys, walks, and avenues in the cemetery in good order and unobstructed so that free access can be had to any lot. The Sexton shall cause a suitable marker to be erected upon the southeast corner of each lot with the number of the lot and the block inscribed thereon.
3. The Sexton shall manage the opening and closing of all interments and disinterments. The Sexton or designee shall maintain a plat of the cemetery; assist any person wishing to purchase in determining the location of any unoccupied lots or parts of lots for sale; and, upon application and payment of the price thereof into the City Recorder's Office, make and execute a certificate of burial rights to the purchaser.

E. REGISTRAR OF BURIALS:

The Sexton or the Sexton's assistant shall be the registrar of burials for the City. Before burying or disinterring any body, the persons having charge of said body shall be required to furnish a copy of the death certificate, or a statement of said death, which shall be recorded in a record kept for that purpose by the Sexton. Such statement, as well as the record, shall include, if known, the name of the person deceased, when and where born, parentage, the date of death, the date of burial, the name of the cemetery, the number of the lot and block where said person is buried, and if disinterred and transferred beyond the corporate limits of Eagle Mountain City.

F. OWNERSHIP AND CERTIFICATES:

1. **Rights of Ownership.** In accordance with UTAH CODE ANN., Section 8-5-7, ownership of a space within the cemetery shall provide only the right to be interred in the cemetery and is not a deed to convey title to real property.
2. **Purchase of Burial Rights.** Residents and nonresidents may purchase burial rights in the cemetery for the price listed on the Exhibit A, Fee Schedule. Residents must provide evidence in a form acceptable to the City that they are a Resident to receive the resident rate. No individual may purchase burial rights for more than eight (8) spaces. The purchase price for burial rights includes perpetual care with no maintenance fee to be assessed. All burial rights purchased for the resident rate shall be clearly marked on a Right to Burial purchase form to indicate that the owner paid the resident price for the cemetery burial rights. Burial rights are not intended for resale.
3. **Certificate of Interment Rights.** Owners of burial rights shall be issued a certificate of interment rights which describes the location of the space within the cemetery. The City shall retain duplicate records of all certificates of interment rights issued by the City. City records shall be the official record of burial rights for all spaces. The certificate of interment

rights shall include a statement that uses of the spaces are subject to these rules, as amended.

4. **Transfer of Burial Right.** A certificate of interment rights for an unoccupied space may be transferred by the owner of the space by: (1) presenting the original certificate of interment rights, (2) completing a right to burial transfer form, (3) paying the certificate fee for each new certificate that is required by virtue of the transfer, (4) either appearing in person and producing photo identification proving the owner's identity, or having the owner's signature on the burial rights transfer form notarized by a licensed notary, and (5) providing evidence in a form acceptable to the City that the transferee is a family member of such owner, or the space has been donated to a person without consideration. The transfer of certificates of interment rights owned by deceased persons shall be completed in accordance with the Utah Uniform Probate Code. If burial rights are purchased at the resident rate and are transferred to a nonresident who is not the burial rights owner's spouse, parent, sibling, child, grandchild or great grandchild, prior to a new certificate being issued, the transferee must pay the difference between the resident rate and the nonresident rate at the time of transfer and pay the certificate fee charge. For every burial right transferred, a new certificate of interment rights shall be issued, and the old certificate of interment rights shall be null and void.
5. **Duplicate Certificates of Interment Rights.** Duplicate certificates of interment rights may be issued upon written application of owner and payment of the burial rights transfer fee. Duplicate certificates of interment rights shall be clearly marked with the words "Duplicate Certificate."
6. **Abandonment and Forfeiture of Burial Rights.** The City may terminate the rights of owners of burial rights in accordance with UTAH CODE ANN. § 8-5-1, *et seq* (unused or unkept burial spaces for 60 years).

G. PROCEDURES:

1. **Caskets or Coffins.** All bodies, remains, or other items buried with the body must be in a casket, coffin, or urn. All caskets, coffins, or urns must be enclosed in a concrete vault that is acceptable to the City.
2. **Excavating Spaces.** No person other than City-authorized personnel shall excavate a gravesite unless authorized in writing by the Mayor or designee.
3. **Application.** The City shall not open a space for interment, provide interment services, or provide disinterment services until the City has received a completed application for interment or disinterment, on the form provided by the City, signed by a relative of the deceased, ecclesiastical leader, or licensed funeral director representing the deceased together with the fee as provided herein.
4. **Proof of Ownership.** If the deceased is the sole owner of the burial rights, the City shall verify the identity of the deceased prior to interment. If the space is owned by someone other than the deceased, written permission in a form acceptable to the City from the owner of the certificate of interment rights shall be required prior to any interment.

5. **Payment of Fees.** The fee to open and close the gravesite, as set forth on Exhibit A, Fee Schedule, shall be paid in full prior to any interment or disinterment.
6. **Additional Fees and Charges.** Fees and costs in addition to those set forth in Exhibit A, Fee Schedule may be charged for special circumstances requiring additional City staff, equipment, or resources. Such additional charges shall be paid in full prior to any interment or disinterment.
7. **Closing of Gravesites.** City personnel shall close any open gravesite promptly after the casket or coffin is placed inside the vault.
8. **Disinterment Services.** The City shall provide disinterment services only for persons buried in a nonbiodegradable vault and in accordance with applicable statutes, rules, and regulations together with the fee as provided herein. The requestor shall arrange for and pay any associated costs for a funeral director to be present at a disinterment. The requestor shall arrange for and pay any associated costs for a licensed vault company to remove the vault and its contents from the gravesite. If the Sexton determines the existing vault has deteriorated to the point that it will not retain its structural integrity during the disinterment, the requesting party shall replace the deteriorated vault with a structurally sound vault at the requestor's expense. The requestor shall have all approvals and authorizations from the county before services will be completed. The requestor shall arrange to dispose of any old vault in a manner meeting federal, state, and local laws.

H. FUNERAL AND INTERMENT:

1. **Prohibited Days.** Graveside services or interments shall not be conducted on any Sunday, New Year's Day, Memorial Day, Independence Day, Pioneer Day, Labor Day, Thanksgiving Day, Christmas Eve or Christmas Day. Additionally, graveside services or interments shall not be conducted the Wednesday prior to Memorial Day through Memorial Day.
2. **Hours of Services.** Graveside services or interment shall be conducted between the hours of 8:00 a.m. and 3:00 p.m., unless otherwise approved by the Mayor or designee.
3. **Length of Services.** Graveside services and/or interments shall not exceed two (2) hours in length unless authorization is provided by the Mayor or designee.
4. **Funeral Processions.** Upon entering the cemetery, all funeral processions shall be under the control and direction of City personnel.
5. **Grave Decorations.** Grave decorations are to be placed only in an existing receptacle or on a grave marker/headstone. No glass, porcelain or other breakable decorations/containers are allowed. No decorations of any kind are allowed in the grass. No hanging devices are allowed in the grass (i.e. shepherd's hooks, wired baskets, etc.) except during winter months (October 15 - March 15). Any grave decorations, funeral designs, flowers, or other items are subject to removal for maintenance (lawn mowing, etc.), which generally occurs each week, with the exception of all national holidays. Decorations will be removed a week after the holiday occurs.

I. RULES AND LANDSCAPING:

1. **Recreational Activity.** No recreational or athletic activities are permitted within the cemetery. Walking or jogging on designated roadways is allowed.
2. **Noise.** All visitors to the cemetery shall maintain a reasonable level of noise to avoid disturbing other visitors to the cemetery. Loud music, shouting, yelling, barking dogs, and other loud noises are prohibited.
3. **Damage or Removal of Headstones or Tombstones.** It is unlawful to damage or remove any headstone, tombstone, or marker located in the cemetery or to desecrate any gravesite within the cemetery.
4. **Animals.** Domestic and companion animals are not allowed on cemetery property unless properly restrained. Properly restrained animals shall not be allowed to urinate or defecate on a gravesite, headstone, grave marker, etc. The owner of a properly restrained animal is responsible to remove any fecal matter his/her animal deposits on cemetery property.
5. **Motor Vehicles.** Motor vehicles shall remain on clearly designated roadways within the cemetery unless provided express consent by City personnel.
6. **Planting of Bushes, Trees or Flowers.** No digging will be allowed within the cemetery. No plants, bushes, trees, shrubs, flowers, or other vegetation may be planted in the cemetery by anyone other than City personnel.
7. **Visitation Hours.** Cemetery hours shall be from 6:00 a.m. to 10:00 p.m. of the same day, unless otherwise posted.
8. **Signs and Advertisements.** No unauthorized signs or advertisements shall be displayed within the cemetery.
9. **Traffic Ordinances.** City traffic ordinances relative to the operation of vehicles and conduct of pedestrians shall be in effect within the cemetery. The speed limit within the cemetery shall be five (5) miles per hour.
10. **Children.** Children under the age of sixteen (16) years of age shall not be allowed within the cemetery unless accompanied by a parent or a chaperone at least eighteen (18) years of age. Exceptions to this rule are allowed for persons attending an authorized funeral, placing flowers on a gravesite of a deceased relative or friend, or performing any other customary respect or respectful actions consistent with the environment maintained within the cemetery.
11. **Surface Grade.** No sections, lots, or spaces shall be raised above the established grade.
12. **Alcoholic Beverages & Tobacco.** Consumption of alcoholic beverages and smoking are not allowed in the cemetery at any time.

J. MARKERS AND MONUMENTS:

1. **Fencing or Dividers.** No space shall be defined by fences, railings, coping, hedges, trees, shrubs, embarking depression, or any other markers to describe its corners or boundaries, unless approved by the Mayor or designee.
2. **Headstones, Tombstones, and Markers.**
 - a. All headstones, markers and monuments shall have a stone or cement base, level with the ground, extending outward from the perimeter of the base of the headstone or marker, which shall be six inches (6") on all sides, with a minimum thickness of four inches (4").
 - b. Headstones and markers in the Angel Garden shall be placed on the western edge of the space, facing east.
 - c. Headstones, markers, and monuments must be installed by a professional installer. The installer must call the Eagle Mountain City Recorder's Office at 801.789.6611 at least two business days in advance to schedule the installation. Installations shall not be conducted on any Sunday, New Year's Day, Memorial Day, Independence Day, Pioneer Day, Labor Day, Thanksgiving Day, Christmas Eve, or Christmas Day. Additionally, installations shall not be conducted the Wednesday prior to Memorial Day through Memorial Day.
3. **Specifications for Raised Headstone, Marker or Monument.**
 - a. For a single raised headstone, marker or monument, the width (side to side) shall not exceed thirty-six inches (36"), not including the six-inch (6") base. The depth shall not exceed twenty-four inches (24"), not including the base. The height shall not exceed forty-eight inches (48"), including the base of the headstone, marker or monument. See Exhibit B for depiction.
 - b. For a double raised headstone, marker or monument, the width (side to side) shall not exceed seventy-six inches (76"), not including the six-inch (6") base. The height and depth specifications are the same as a single raised headstone, marker or monument. See Exhibit B for depiction
4. **Specifications for Flat Markers.** Flat markers shall not be smaller in surface measurement than twelve inches (12") by eighteen inches (18"), not including the base, and not larger than twenty-four inches (24") by thirty-six inches (36"), not including the base. See Exhibit B for depiction
5. **Materials.** All headstones, tombstones, or markers must be made of real bronze, glazed granite or other permanent materials acceptable to the Mayor or designee. Headstones, tombstones, or markers shall not be made of wood, sandstone, or any other material which is susceptible to decay.

6. **Vases.** All permanent vases placed in the cement or stone base of the marker or monument shall be recessed to ground level when not in use. Receptacles in the monument itself are allowed provided they do not project horizontally beyond the base of the monument.
7. **Liability for Damage.** The City shall not be held liable for damage to headstones, tombstones, or markers, including any damage caused during cemetery maintenance or resulting from the City moving or transferring the headstones, tombstones, or markers for interment purposes.

K. DECORATING BURIAL SPACES AND OTHER REGULATIONS:

1. **Removal of Items.** If the City removes grave decorations, funeral designs, flowers, or other items, the City shall attempt to retain such items for a period of one week before being discarded. Notwithstanding the foregoing, the City shall not be liable for any items that are discarded, damaged, or destroyed.
2. **Theft or Loss of Personal Belongings.** The City is not responsible for the theft or loss of personal belongings in the cemetery.

**EXHIBIT A
FEE SCHEDULE**

BURIAL SPACE

Resident	\$550
Non-Resident	\$1,000

ANGEL GARDEN SPACE

Resident	\$275
Non-Resident	\$500

INTERMENT

Adult	\$300
Infant	\$200
Interment of Cremated Remains	\$200
Disinterment	\$1500

OTHER FEES/SERVICES

Headstone Inspection	\$35
Saturday Interment	Additional \$300
Transfer Fee (Per Certificate)	\$50

Exhibit B Headstone Specifications

Headstones must be installed by a professional installer. Please have the monument company contact the Eagle Mountain City Recorder's Office at 801.789.6611.
A \$35 headstone inspection fee is required.

Raised Headstones

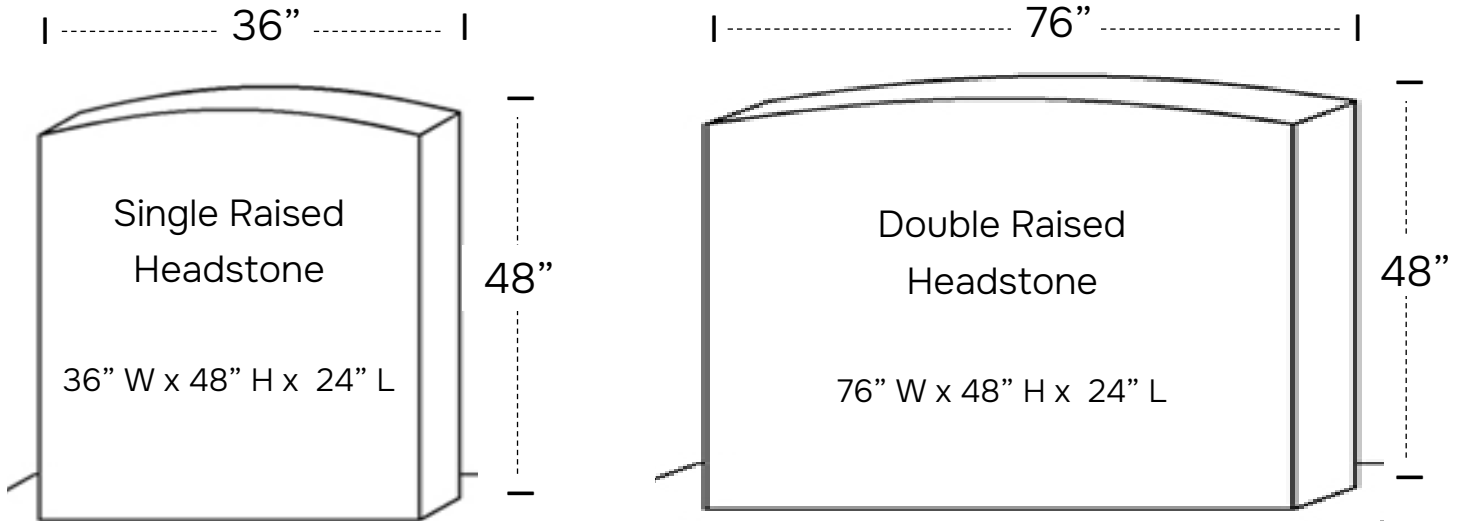

Base/Border

All headstones and monuments must have a stone or concrete base/border.
Borders must extend 6 inches on all sides of the headstone/marker with a minimum depth of 4 inches.

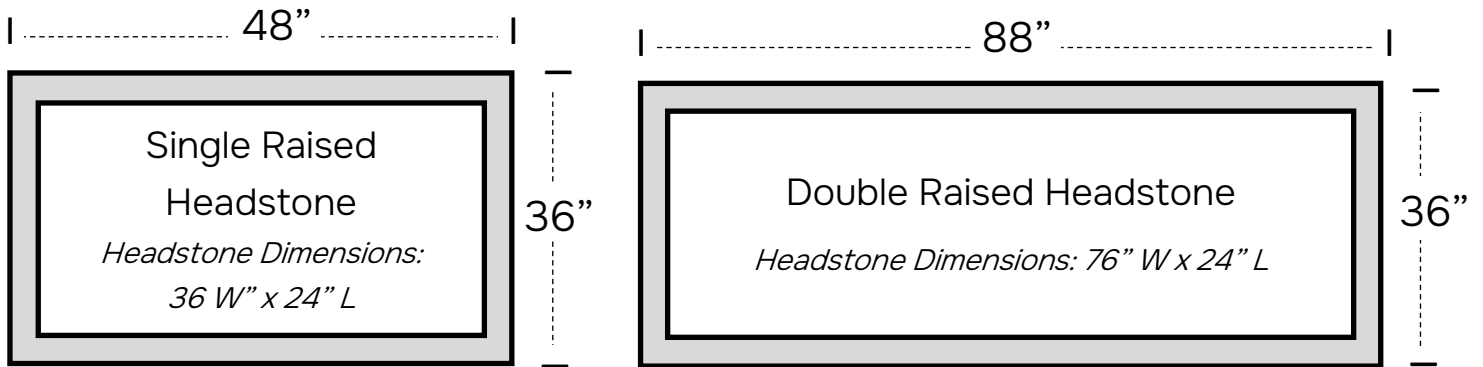

Flat Markers

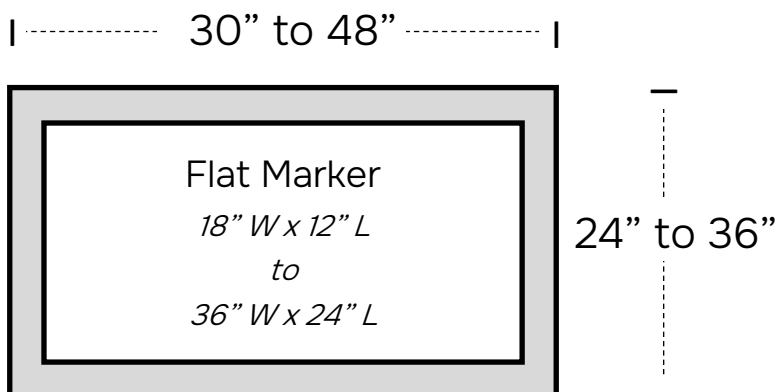

Angel Garden Markers

Only Flat Markers are permitted in the Angel Garden.